



Thermocouple Input Module

Delivery Code
3DAY

EZIO-4THI



EZIO-4THI
\$139

Terminal Block
300 Volt/10 Amp/
14AWG UL Rating

Module Specifications	
Number of Channels	4, differential
Common Mode Range	-1.5 VDC to +4.0 VDC
Common Mode Rejection	100dB min. @ VDC 50/60Hz
Input Impedance	5MΩ
Absolute Maximum Ratings	Fault-protected inputs to ±50 VDC
Accuracy vs. Temperature	± 15ppm/°C max. 0-1.25V ±35 ppm/°C max. (including max. offset change)
PLC Update Rate	4 channels per scan
Base Power Required	10mA @ 3.3 VDC supplied by base
Operating Temperature	32° to 140°F (0° to 60°C)
Storage Temperature	-4° to 158°F (-20° to 70°C)
Relative Humidity	5 to 95% (non-condensing)
Environmental Air	No corrosive gases permitted
Vibration	MIL STD 810C 514.2
Shock	MIL STD 810C 516.2
Noise Immunity	NEMA ICS3-304
Replacement Terminal Block	EZIO-TERM11CJC (comes with CJC)

Pinout Information	
Pin No.	4 Thermocouple Input
1	CHAN1 + (Input)
2	CHAN1 - (Input)
3	CHAN2 + (Input)
4	CHAN2 - (Input)
5	CHAN3 + (Input)
6	CHAN3 - (Input)
7	CHAN4 + (Input)
8	CHAN4 - (Input)
9	+ 5 VDC
10	Vout (Temp. Sensor)
11	Analog GND

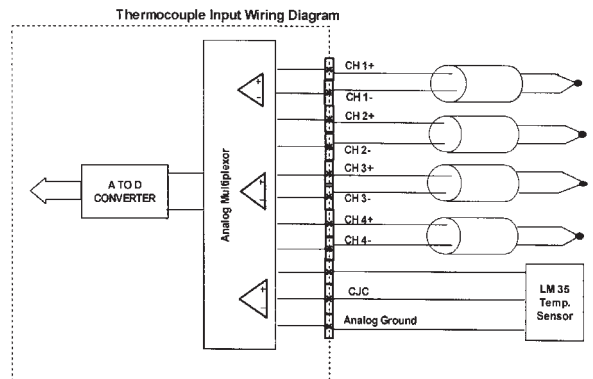

Thermocouple Specifications	
Input Ranges in C	Type J -40 to 340°C Type K -80 to 450°C Type S 25 to 720°C Type T -180 to 330°C
Display Resolution	Type J,K,T ± 0.1°C; Type S ± 1°C
Cold Junction Compensation	Automatic
Conversion Time	1ms per channel
Warm-Up Time	30 minutes typically ± 1°C repeatability
Linearity Error (End to End)	± 1°C max. ± 0.5°C typical
Maximum Inaccuracy	± 3°C (excluding thermocouple error)

* IMPORTANT

This module requires an EZPLC with Firmware Revision **B.0** or Later.

To check the firmware revision of your EZPLC:

Using the EZPLC Editor Software access the menu item **EZPLC > INFORMATION...** a window will open displaying the current **EXEC Software** and **BOOT Software** revisions.

To upgrade the firmware:

Download firmware at www.EZAutomation.net (downloads section). Once downloaded, use EZPLC editor and select **Setup>Upgrade Firmware** menu item.